

DESIGN, INSTALLATION AND PERFORMANCE OF JACK-IN-PIPE ANCHORAGE SYSTEM FOR TEMPORARY RETAINING STRUCTURES

S. S. LIEW¹, Y. C. TAN² and C. S. CHEN³

ABSTRACT

The design, installation and performance of an uncommon patented anchorage system, namely the jack-in pipes, are presented in this paper. This anchorage system has been used as the support system for a temporary excavation of 9m deep basement in loose sandy alluvium deposits overlying Kuala Lumpur limestone. Jack-in pipe system has advantages of rapid installation, practically no grout curing time prior to anchorage stressing and easy removal after used. However, there are also some disadvantages of this anchorage system, such as short penetration length due to limitation of reaction system, poor penetrability in stiff soils and obstructions, limited pipe inclination, complication of wall performance affected by reaction system and difficulties in backfilling the voids after removal of pipes.

This paper discusses the design concept, problems associated with the installation methods, construction control and performance of this anchorage system. The design theory with consideration of the change in radial stress of pipe due to pipe insertion, the ultimate skin resistance at the pipe/soil interface and the role of bending stiffness of pipe are discussed. Construction control is another important aspect to warrant success of this anchorage system. Results of six numbers of pull-out tests carried out on this anchorage system are presented. In these tests, the jack-in pipes at different depths of overburden soil are pulled to failure and the test results show a satisfactory performance of this anchorage system.

INTRODUCTION

This paper summarises the pull-out test results of an unusual patented anchorage system using hollow steel pipes jacked into the retained ground as both the anchorage and the reinforcing elements. This innovative anchorage system was firstly intended to retain a basement construction with maximum excavation depth of 9m in sandy alluvium subsoil. In this case history, the conforming design for the wall anchorage system was the conventional ground anchorage with fixed length in limestone bedrock. Owing to the sandy nature of the subsoil, there was excessive washing-out of granular material during the construction of trial anchors and causing undue ground settlement behind the basement wall. Because the site was surrounded by major roads and buildings, excessive settlement due to the loss of material was not acceptable. In addition, the variation of limestone bedrock posed uncertainties in the ground anchorage design and construction, which has to derive anchorage forces solely from the bedrock because the overburden subsoil is considerably weak. In view of all these factors, an alternative anchorage system was considered. Jack-in pipe anchorage system was introduced to the project as an alternative anchorage system.

DESCRIPTION OF PROJECT

The site is located in one of the busiest main road in the middle of Kuala Lumpur, Malaysia. The excavation was about 8m away from the main road. Due to the close proximity to the main roads, it was decided to put up a row of Section 16W sheet pile wall supported by two rows of conventional anchorage into the limestone to facilitate the excavation at the main roads. Toe pins were provided for sheet piles with short penetration due to shallow limestone. The rest of the excavation was open cut with stable slope

¹ S. S. Liew, Gue & Partners Sdn Bhd, 1-2, The Metro Centre, Bandar Tasik Selatan, 57000 Kuala Lumpur, Malaysia.

² Y. C. Tan, Gue & Partners Sdn Bhd, 1-2, The Metro Centre, Bandar Tasik Selatan, 57000 Kuala Lumpur, Malaysia.

³ C. S. Chen, SSP Geotechnics Sdn Bhd, Level 6, Wisma SSP, 1 Jalan SR 8/3, 43300 Seri Kembangan, Malaysia.

configuration. Figure 1 shows the plan view of the excavation. Figures 2 and 3 show the view of the installed jack-in anchors at the sheet pile wall and the set up of a pull-out test.

Three rows of jack-in pipes were installed at reduced levels RL+31.0m, RL+28.5m and RL+27.0m respectively. The lateral pipe spacing was 1.05m centre-to-centre at the top level and the 0.525m at the two lower levels.

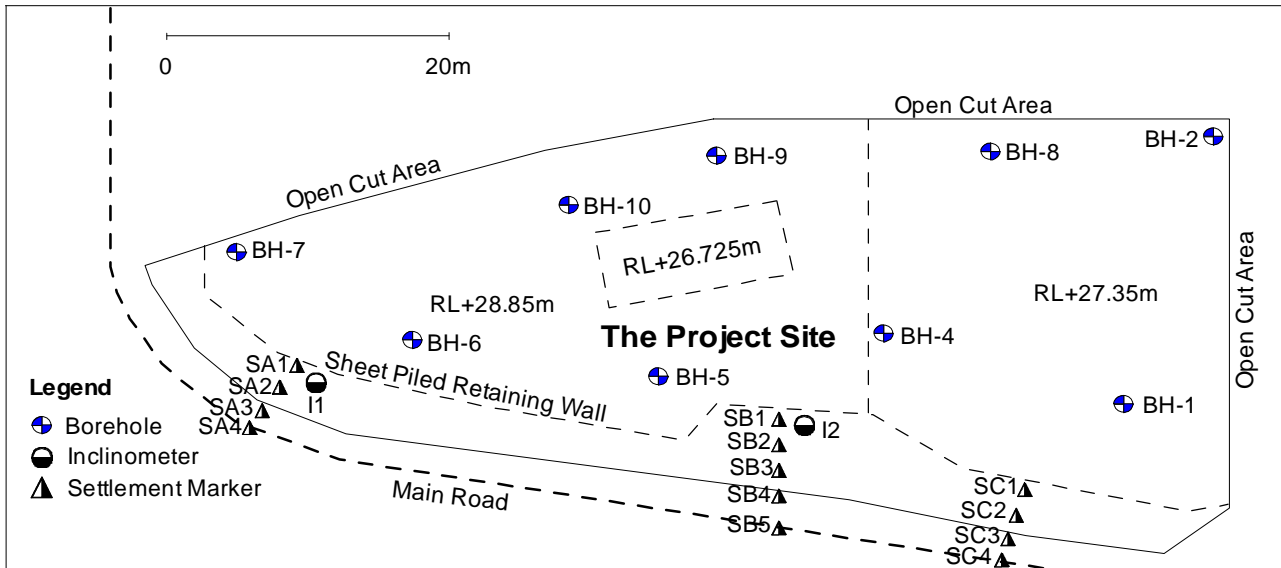

Figure 1 : Plan View of the Site



Figure 2 : The Installed Jack-In-Pipe Anchorages at the Sheet Pile Retaining Wall of 9m High



Figure 3 : View of the Pull-Out Test Arrangement

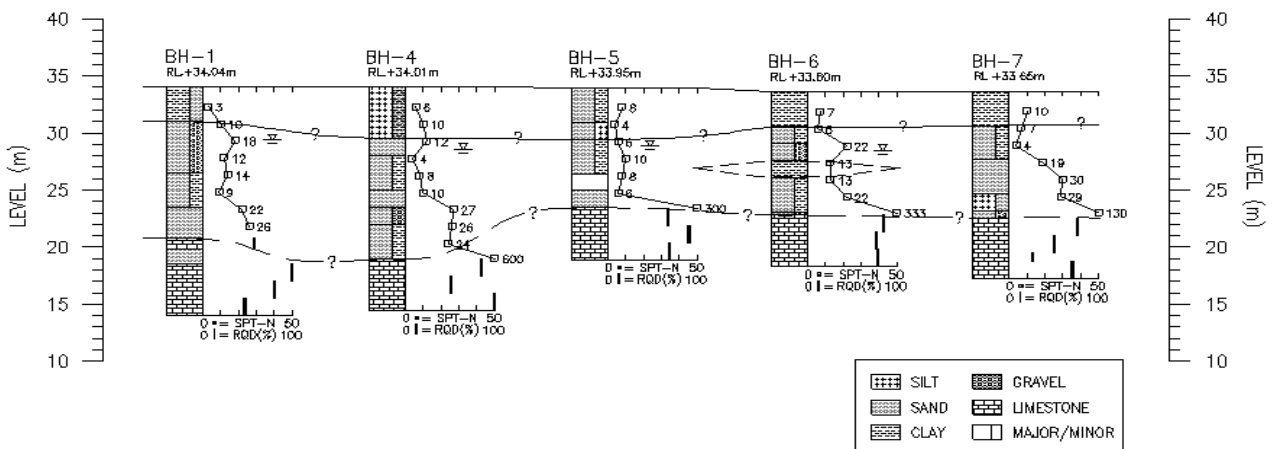

Figure 4 : Typical Subsoil Profile

GEOLOGICAL CONDITIONS

The general subsurface profile of the site is shown in Figure 4. The site is underlain by alluvium soils of Quaternary period. The top 3m of the subsoil consists of firm, intermediate plasticity Clay, and followed by minimum 17m thick of loose, well-graded silty Sand. Kuala Lumpur Limestone of middle to upper Silurian age is found at the depth of about 20m but significant variation of bedrock profile. The SPT 'N' values at the upper cohesive layer and the lower cohesionless layer are about 8 to 10 and 2 to 24 respectively, but with representative values of 8 to 10. The Unconfined Compression Strength (UCS) of the Limestone ranges from 44MPa to 92MPa. Groundwater table is about 5 to 6m below existing ground level.

CONSTRUCTION SEQUENCE

The construction sequence of this anchorage system is as follows and as shown in Figure 5:

- i. Establish a reaction system for the jacking of the steel pipes into the retained ground. In the case history presented in this paper, the retaining wall formed part of the reaction system.
- ii. The retaining wall is to be in place and with the cut holes at various levels for the access of the pipes to be jacked into the ground.
- iii. The reaction frame is to be structurally attached to the retaining wall using the high tensile bolts to take the pulling reaction. The angle of insertion of the pipe can be adjusted in this stage. In normal cases, maximum downward inclination of 15° is allowed.
- iv. Mild steel pipe of $\phi 114\text{mm}$ (OD) and 4.5mm thick is to be placed inside the reaction frame with the hydraulic jack at the end of the pipe. Steel bearing plate is to be placed and supported by grooves along the reaction frame. The hydraulic jack is then jacked against the steel bearing plate.
- v. After every stage of jacking, the ram is retracted, the bearing plate and the jack are relocated for the next stage of jacking.
- vi. Jointing of pipe is necessary when longer penetration of the pipe is required.
- vii. Continue jacking the pipe until the designed length or 2.0 times of the working capacity of the pipes is reached whichever is longer. Discount for the contribution from tip resistance during jacking in process will be made and the required penetration length will be determined from the estimated skin resistance with adequate safety factor as in normal engineering practice.
- viii. Connection between the pipes and the wall is provided by a capping steel plate on the wall supporting an adaptor with bolt welded to the pipe. Tensioning force is then applied by tightening the bolt with nominal torque.

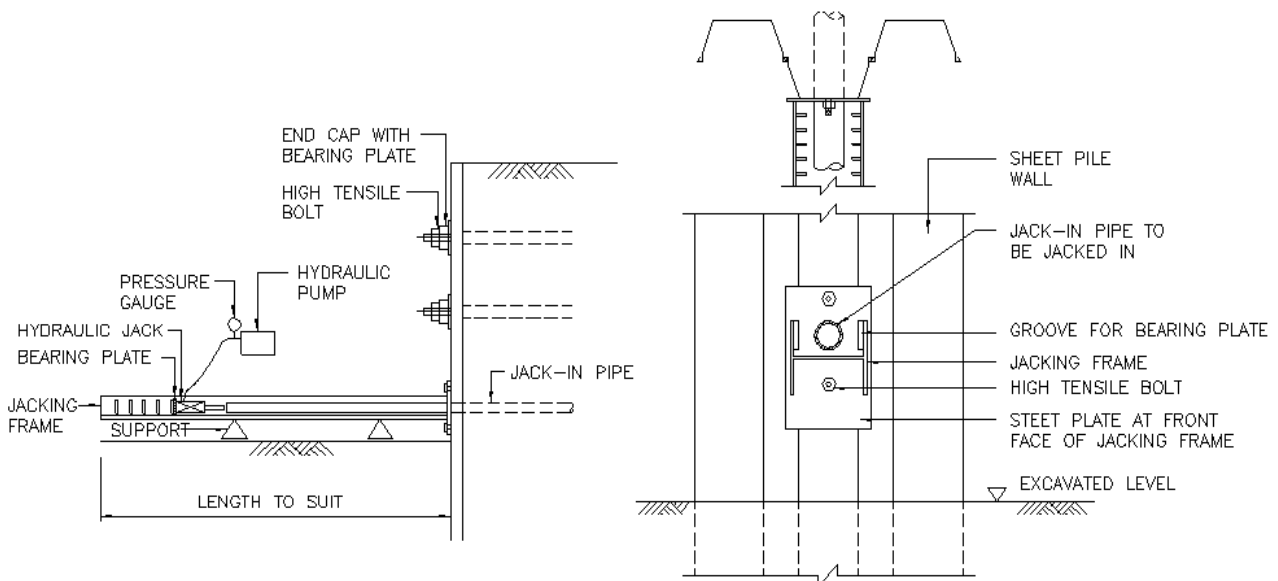

REACTION SYSTEM – JACK-IN PIPE ANCHOR

Figure 5 : Jacking-In Process of Pipe Anchorage

ADVANTAGES AND DISADVANTAGES

Disadvantages and advantages of the jack-in pipe anchorage system are highlighted as follows:

Disadvantages

1. Poor penetrability in certain soil conditions, like boulders, stiff cohesive soils and dense cohesionless soils or any other physical obstructions. It is somehow required to base on the so-called “best estimate” of the tip resistance in the known subsoil conditions to make extra allowance for the required jacking force.
2. Like other anchorage system, encroachment beyond the wall boundary is required for the installation of pipe anchors.
3. Complication of the wall performance if reaction system is to be established on the retaining wall. Instead of providing the retaining forces to the wall, the installation of jack-in pipes may aggravate the wall deflection due to the pulling reaction on the wall, especially for flexible wall type like sheet pile wall. However, this can be overcome if an independent reaction system is used.
4. Empty holes left in the ground after removal of the jack-in pipes, which may cause occurrence of sinkholes and settlement due to ground loss if not filled up timely and properly.
5. The hollow pipe provides a convenient flow path for the groundwater behind the wall. Sealing the annulus between the pipe and the hole on the wall is required to prevent washing-out of ground materials, especially if the groundwater level is high.

Advantages

1. Fast operation and low-cost anchorage system. The equipment used is highly mobile and flexible.
2. No waiting time for grout curing.
3. Easy removal of anchorage element after use.
4. Unlike traditional anchor, in which the anchor will have to be abandoned after a failure pull-out test, jack-in anchor can still mobilise pull-out resistance as it relies on skin friction rather than bonding force. Therefore, proof load test can be practically carried out at every jack-in pipe without the fear of failure.

In most cases, if quality construction control is implemented at site, the advantages likely prevail the disadvantages.

THEORETICAL MODELLING

In the presented case history, the design of the pipe anchorage was initially based on the conventional ground anchor design. There were free length in the active zone and fixed length at the undisturbed zone. The required working capacities of the pipe anchor at various levels were then derived. The forming of free length was by the use of a collar attached on the beginning of the free length portion to expand the soil wall when jacking the pipe and applying grease over the free length to sleeve the pipe.

The actual behaviour of this anchorage system would be more like the reinforced element in soil-nailed wall. With the significant higher flexural stiffness of the pipe, it can also provide better vertical support to the retained soil in the active wedge, which has the tendency to move outwards and downwards from the wall, and hence minimise the ground settlement as what can be expected in the soil-nailed wall, which needs movements to mobilise the capacity of the nails. Jewell and Pedley (1990) have taken the bending stiffness of soil nail reinforcement into consideration in the soil nailing design.

The pull-out load of the pipe is theoretically proportional to the integrated sum from the radial stress acting over the pipe surface. The induced radial stress can be derived from the cavity expansion theory. However, the distribution of radial stress around the pipe at the slip interface in service condition should be adjusted for the bending action of pipe/soil interaction. Bridle (1989) has illustrated procedures for soil nail design.

The role of the reinforcing element in the soil/structure interaction of an unloading condition is to provide shear force and axial force, which is developed through bending stiffness of the pipes, to achieve an overall reinforcing improvement. The walling is more to retain the soil at vertical or sub-vertical slope, which is not effectively reinforced, particularly at the tip of reinforcement.

INTERPRETATION OF PULL-OUT TEST RESULTS

The respective pull-out test results at various levels are shown in Figure 6. The interpreted details are tabulated in Table 1.

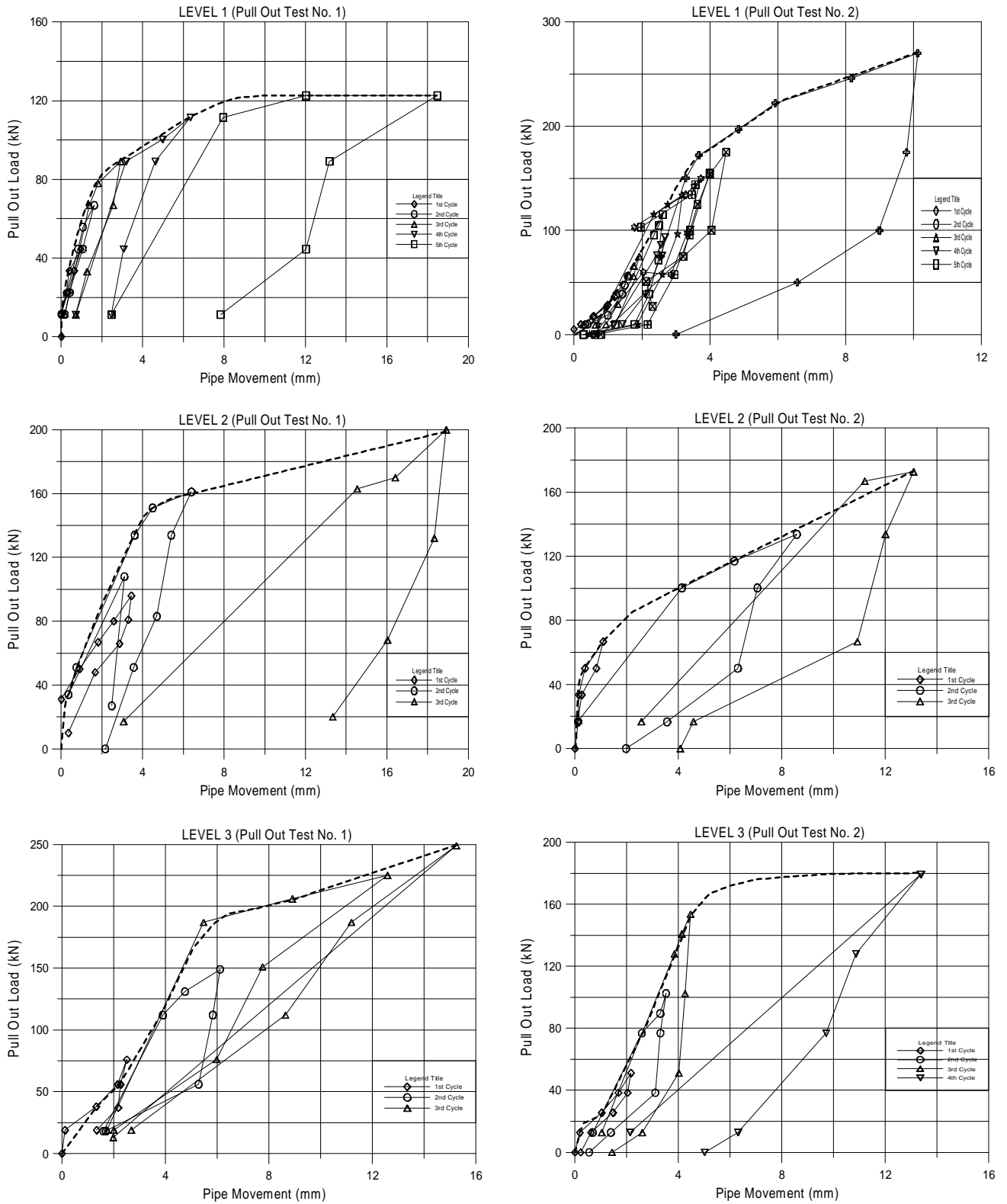

Figure 6 : Pull-Out Tests for 3 Levels of Jack-In-Pipe Anchor

Table 1 : Summary of Pull-Out Test Results

Test No	Anchor Level	Level (RL)	Date of Installation	Date of Testing	Time Lapsed (Day)	Pipe Size (mm)	Free Length (m)	Fix Length (m)	Ultimate Load (kN)	Skin Resistance Factor, β
T1-1	1st	+31.0m	18/03/96	05/04/96	18	100	4	8	122	0.90
T1-2	1st	+31.0m	19/04/96	24/04/96	5	114	4	11	280	1.32
T2-1	2nd	+28.5m	19/04/96	22/04/96	3	114	2	10	170	0.48
T2-2	2nd	+28.5m	24/04/96	04/05/96	10	114	2	10	185	0.52
T3-1	3rd	+27.0m	30/04/96	02/05/96	2	114	0	9	180	0.50
T3-2	3rd	+27.0m	04/05/96	07/05/96	3	114	0	9	225	0.63

Note : Ground level : RL+34.0m

Two inclinometers, namely I1 and I2, were installed in the retained soil immediate behind the sheet pile wall to measure the performance of the retaining system. Inclinometer I1 was installed 1m into the shallow limestone at about 12m below the ground level whereas Inclinometer I2 was also socketed 1m into the deeper bedrock at about 19m below ground level. The lateral ground movements captured by the two working inclinometers are shown in Figure 7. The maximum lateral ground movements at the end of excavation are in the range of 106mm to 110mm. The maximum movements occurred at the ground surface. The lateral deflection profile of the retained soil tends to indicate that the wall almost performed like a cantilever wall.

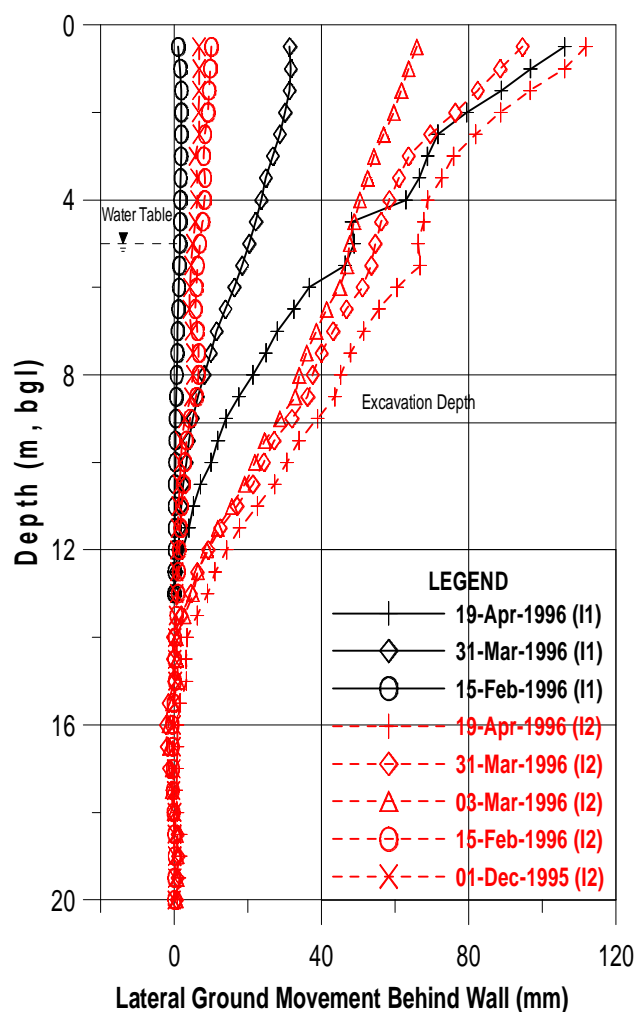

Figure 7 : Lateral Ground Movements Behind Wall

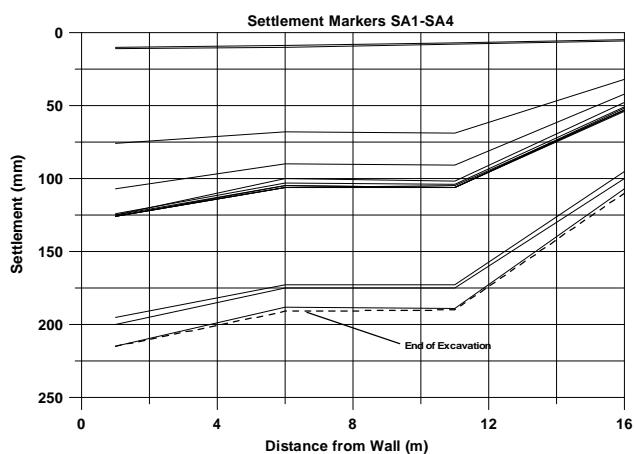

Figure 8 : Settlement Profile for Markers SA1-SA4

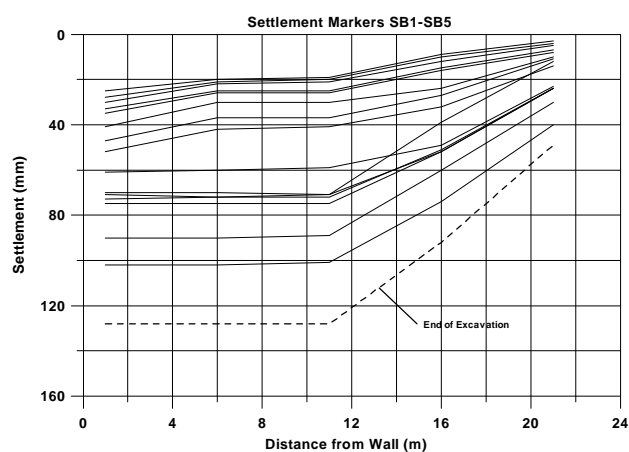

Figure 9 : Settlement Profile for Markers SB1-SB5

The settlement profiles of the three (3) sets of settlement markers are shown in Figures 8, 9 and 10 respectively. The maximum settlement is about 218mm, which is located at Marker SA1. This could be due to some washing-out of material during trial installation of the two conventional ground anchors. In general, the magnitude of settlements behind the wall at the end of excavation is in the range of 125mm at the wall and tapers off after about 20m to 25m away from the wall.

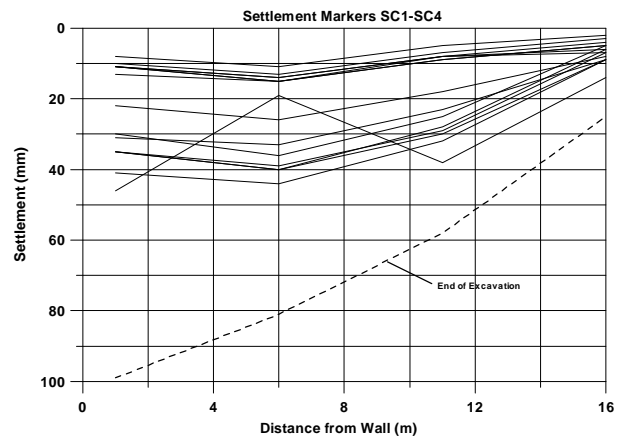

Figure 10 : Settlement Profile for Markers SC1-SC4

DISCUSSIONS

The following discussions will concentrate on the pull-out test results for this anchorage system:

- i. There are some time effects on the pull-out resistance. Generally, the skin resistance increases with time in the granular soils. But in cohesive soils, the skin resistance reduces with time. However, there is insufficient data to substantiate the reduction of skin resistance in cohesive soil.
- ii. Based on the effective stress approach, the calculated skin resistance factor, β , for the jack-in pipes ranges from 0.44 to 1.32 with majority of the values fall within 0.50 to 0.63. These values are larger than those derived from pile skin friction, which is normally in the range of 0.35 to 1.0 for granular soils (Combarieu, 1985). Whereas, in this case the vertical effective stress is almost constant for the pipes.
- iii. In certain pull-out test results, for instances, Test No. 2 at Level 1 and Test No. 1 at Level 3, low pull-out stiffness is observed at the beginning of the test. This could be due to the locked-in compression stresses in the pipe as the result of jacking. This compressive stress was triggered and released during the pull-out test. It is believed that the occurrence of the locked-in compressive stress can be isolated incidence but, theoretically, it can occur in most of the pipes.
- iv. The lateral soil deformations behind the wall are less than 120mm, which is about 1.3% of the depth of excavation.
- v. The settlement profiles from the settlement markers indicate that the settlement immediately behind the wall is about 120mm and tapered off at a distance of about 20m to 25m from the wall except Markers SA1 to SA4, which was probably due to the excessive ground loss during installation of trial anchors. The settlement profiles fall near to the Zone I in the settlement chart by Peck (1969), which is for sand and soft to hard soil with average workmanship.

RECOMMENDATIONS

It is recommended to look into the following areas for further study of the behaviour of this relatively new anchorage system for future improvement:

1. Instrument the pipe anchorage to observe the radial and axial stresses and distribution of these stresses over the whole length of the pipe and around the pipe during installation, pull-out test and service conditions. Instrumentation of the overall retaining system is also recommended to observe the soil/structure interaction and the reinforcing effects from bending stiffness of the pipes.
2. Monitor the forming of soil plug within the pipes during jacking in process, which has implication of the increase of radial stress on the pipe due to cavity expansion.
3. Prevent establishing the reaction system on the retaining wall as the pulling reaction force will aggravate the wall deflection. The reaction system can utilise the pull out capacity of the adjacent pipe anchors by attaching the reaction system on them. This also will release the locked-in compressive forces in the pipe anchors.

4. The jointing between two pipes should not form an enlargement of hole in the embedded soil. Such enlargement will act as a collar to reduce the radial stress on the pipes, hence reduce the skin resistance.

CONCLUSIONS

The results of six pull-out tests at various levels of a basement excavation are presented. The following conclusions are drawn:

1. The calculated skin resistance factor, β , in the effective approach for estimation of the pull-out capacity of the jack-in pipes ranges from 0.50 to 0.63 in granular soils with two exceptional cases as high as 0.9 to 1.32 in the cohesive soils.
2. This anchorage system is suitable for excavation works with weak subsoil conditions at the retained soils and preferably with excavation depth not exceeding 10m. The deeper the excavation is, the larger the ground settlement and its extent will be.
3. Measures for futures improvement of this anchorage system are discussed.

REFERENCES

1. Bridle, R. J., (1989), "Soil Nail – Analysis and Design, Ground Engineering", September, 1989, pp. 52-56.
2. Combarieu, O., (1985), "Frottement Negatif Sur Les Pieux, Rapport de Recherche LPCN 136", Laboratoire Centrale des ponts Et Chaussees, pp. 151.
3. Jewell, R. A. and Pedley, M. J., (1990), "Soil Nailing Design: The Role of Bending Stiffness", Ground Engineering, March, 1990, pp. 30-36.
4. Peck. R. B., (1969), "Deep Excavations and Tunneling in Soft Ground", Proc. Int. Conf. Soil Mech. Found. Eng., Mexico City, 1969.